

# NSHTÖU-JZ /-OZ

FLEXIBLE CABLES FOR REELING APPLICATIONS - CONTROL AND DATA - 0.6 / 1 KV

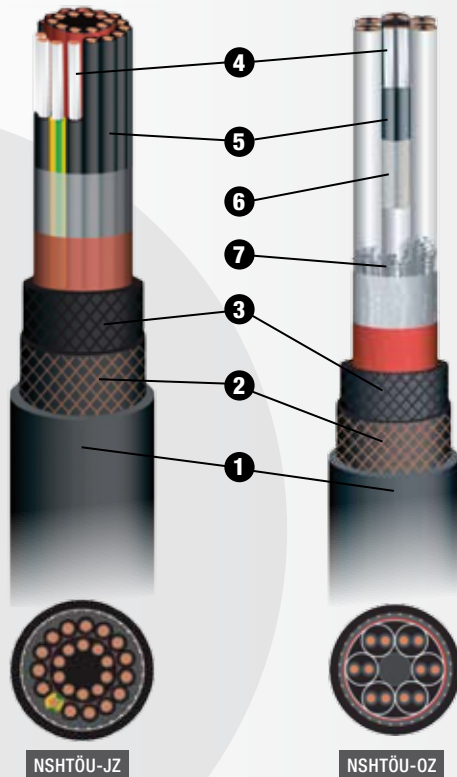

All the very stringent characteristics of the insulating cover and the sheath make the cable suitable for use with reeling systems such as power supply of moving machines. In addition to its excellent mechanical characteristics, the **polychloroprene** sheath has a good resistance to wear combined with a high flexibility over a large range of temperatures.

## Design

- ❶ Black polychloroprene outer sheath
- ❷ Synthetic anti twist yarns
- ❸ Polychloroprene inner sheath
- ❹ Tinned copper cores
- ❺ Insulation:
  - Phase: black HEPR compound with printed numbers
  - Earth: green / yellow HEPR compound
- ❻ Shield: tinned copper braid screen
- ❼ Textile filler

*Short lay-length assembled conductors wrapped in a semi conductive strip.*

## Standards

- VDE 0250 part 814
- VDE 0298 part 4 (core temperature in service)
- Flame resistance: class C3 (not tested)

## Conditions of use

- Suitable for all types of spool in adequacy with the minimum bending radius.

## Voltage

- 0.6 / 1 kV - Low Voltage

## Linear reeling speed

- NSHTÖU-JZ: 180 m/min max
- NSHTÖU-OZ: 60 m/min max

## Ambient temperature

- From -30 up to +90°C (see table of de-rating factors next page).



### Cables NSHTÖU-JZ /-OZ Technical Data

Number of Cores × Nominal C.S.A. mm <sup>2</sup>	Outer Diameter		Unsheathed Cable Diameter mm	Linear Weight kg/m	Traction Maxi daN	Current Carrying Capacity A	Voltage Drop V/A.km	Dynamic Short Circuit Current kA	Min Bending Radius mm
	Min mm	Max mm							
<b>NSHTÖU-JZ Control Cables</b>									
4 G 1.5	13.1	15.2	10.7	0.285	9.0	23	24	0.19	87
5 G 1.5	14.0	16.0	11.8	0.320	11.3				93
7 G 1.5	15.8	17.9	14.3	0.415	15.8				115
12 G 1.5	19.1	21.2	16.9	0.585	27.0				134
18 G 1.5	21.6	23.7	19.7	0.765	40.5				152
24 G 1.5	25.6	27.6	23.0	1.040	54.0				177
30 G 1.5	26.6	28.7	24.7	1.140	67.5				189
36 G 1.5	28.6	31.8	26.5	1.370	81.0	201			
4 G 2.5	14.3	16.3	12.5	0.355	15.0	30	14	0.32	103
5 G 2.5	15.2	17.3	13.8	0.410	18.8				110
7 G 2.5	18.1	20.2	16.6	0.570	26.3				127
12 G 2.5	21.1	23.2	19.5	0.760	45.0				149
18 G 2.5	24.7	26.8	23.1	1.070	67.5				181
24 G 2.5	28.6	31.8	27.4	1.450	90.0				204
30 G 2.5	30.0	33.0	29.0	1.600	112.5				212
36 G 2.5	31.8	35.0	31.2	1.850	135.0	230			
<b>NSHTÖU-OZ Data Transmission Cables</b>									
3×(2×1.5)bl	21.4	23.5	19.5	0.740	13.5	23	24	0.19	155
6×(2×1.5)bl	28.3	30.3	26.5	1.210	27.0	23	24	0.19	200
6×(2×2.5)bl	30.6	33.6	29.0	1.570	45.0	30	14	0.32	225
19×2.5+5×1(bl)	30.6	33.8	29.0	1.580	71.3	30	14	0.32	225
19×2.5+5×1.5(bl)	30.6	33.8	29.0	1.630	71.3	30	14	0.32	225
25×2.5+5×1(bl)	32.6	35.8	31.0	1.820	93.8	30	14	0.32	215
25×2.5+5×1.5(bl)	32.6	35.8	31.0	1.850	93.8	30	14	0.32	215

#### Recommendations

- Amperage de-rating factor for reeling applications: 0.85
- De-rating factors in relation to the ambient temperature above 30°C:

30°C up to 40°C	0.90
40°C up to 50°C	0.80
50°C up to 55°C	0.74
55°C up to 60°C	0.65

- Recommended voltage drop limits:

Usual	5%
Lighting	3%
Frequency inverter	2.5%

#### Installation

- Minimum distance between two guiding devices:  $L_{min} = 20 \times \text{cable O.D.}$

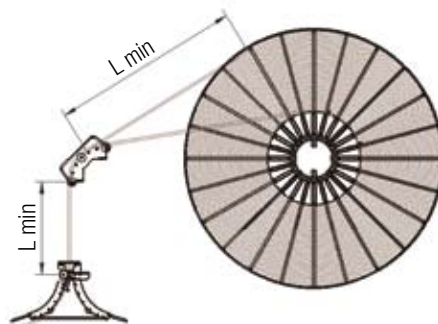

- Deflection angle (if  $\varnothing r < \text{bending radius}$ ) = 15° max for laying on rollers

