

Push Button Pendants

80 Series



CONDUCTIX INCORPORATED

The technical data and images which appear in this manual are for informational purposes only. **NO WARRANTIES, EXPRESS OR IMPLIED, INCLUDING WARRANTIES OF MERCHANTABILITY OR FITNESS FOR A PARTICULAR PURPOSE, ARE CREATED BY THE DESCRIPTIONS AND DEPICTIONS OF THE PRODUCTS SHOWN IN THIS MANUAL.** Conductix makes no warranty (and assumes no liability) as to function of equipment or operation of systems built according to customer design or of the ability of any of its products to interface, operate or function with any portions of customer systems not provided by Conductix.

Seller agrees to repair or exchange the goods sold hereunder necessitated by reason of defective workmanship and material discovered and reported to Seller within one year after shipment of such goods to Buyer.

Except where the nature of the defect is such that it is appropriate, in Seller's judgment, to effect repairs on site, Seller's obligation hereunder to remedy defects shall be limited to repairing or replacing (at Seller's option) FOB point of original shipment by Seller, any part returned to Seller at the risk and cost of Buyer. Defective parts replaced by Seller shall become the property of Seller.

Seller shall only be obligated to make such repair or replacement if the goods have been used by Buyer only in service recommended by Seller and altered only as authorized by Seller. Seller is not responsible for defects which arise from improper installation, neglect, or improper use or from normal wear and tear.

Additionally, Seller's obligation shall be limited by the manufacturer's warranty (and is not further warranted by Seller) for all parts procured from others according to published data, specifications or performance information not designed by or for Seller.

Seller further agrees to replace or at Seller's option to provide a refund of the sales price of any goods that do not conform to applicable specifications or which differ from that agreed to be supplied which non-conformity is discovered and forthwith reported to Seller within thirty (30) days after shipment to the Buyer. Seller's obligation to replace or refund the purchase price for non-conforming goods shall arise once Buyer returns such goods FOB point of original shipment by Seller at the risk and cost of Buyer. Goods replaced by Seller shall become the property of Seller.

There is no guarantee or warranty as to anything made or sold by Seller, or any services performed, except as to title and freedom from encumbrances and, except as herein expressly stated and particularly, and without limiting the foregoing, **there is no guarantee or warranty, express or implied, of merchantability or of fitness for any particular purpose or against claim of infringement or the like.**

Seller makes no warranty (and assumes no liability) as to function of equipment or operation of systems built to Buyer's design or of the ability of any goods to interface, operate or function with any portions of Buyer's system not provided by Seller.

Seller's liability on any claim, whether in contract, tort (including negligence), or otherwise, for any loss or damage arising out of, connected with, or resulting from the manufacture, sale, delivery, resale, repair, replacement or use of any products or services shall in no case exceed the price paid for the product or services or any part thereof which give rise to the claim. In no event shall Seller be liable for consequential, special, incidental or other damages, nor shall Seller be liable in respect of personal injury or damage to property not the subject matter hereof unless attributable to gross misconduct of Seller, which shall mean an act or omission by Seller demonstrating reckless disregard of the foreseeable consequences thereof.

Seller is not responsible for incorrect choice of models or where products are used in excess of their rated and recommended capacities and design functions or under abnormal conditions. Seller assumes no liability for loss of time, damage or injuries to property or persons resulting from the use of Seller's products. Buyer shall hold Seller harmless from all liability, claims, suits and expenses in connection with loss or damage resulting from operation of products or utilization of services, respectively, of Seller and shall defend any suit or action which might arise there from in Buyer's name - provided that Seller shall have the right to elect to defend any such suit or action for the account of Buyer. The foregoing shall be the exclusive remedies of the Buyer and all persons and entities claiming through the Buyer.

1.0 SPECIFICATIONS

- 1.1 Mechanical Specifications
- 1.2 Electrical Specifications
- 1.3 Environmental Specifications

2.0 ASSEMBLY

- 2.1 Disassembly of the enclosure
- 2.2 Mounting Switches
- 2.3 Mounting mushroom head selector and key switches
- 2.4 Cable installation
- 2.5 Button legends
- 2.6 Vertical legends
- 2.7 Reassembly of the enclosure

3.0 SWITCH SCHEMATICS

1.0 SAFETY

1.1 Mechanical Specifications

1.1.1 Recommended cable: Pendant Control cable or equivalent, copper conductors 75°C

1.1.2 Bushings are available for cables ranging from 0.30" to 1.16" in diameter.

1.1.3 External Strain Relief: An external strain-relief tie point on the bushing collar has been supplied for the connection of an external-relief wire attached to the upper junction box of the cable. Pre-assembled pendants are supplied with an "S" hook for strain relief attachment.

1.1.4 Torque values:

- Enclosure Screws: 10in-lbs.
- Switch Mounting Screws: 20in-lbs.
- Internal Cable Clamp: 10in-lbs.
- Bushing Clamp: 25in-lbs.
- Terminal Screws: 10in-lbs.

1.2 Electrical Specifications

1.2.1 Contacts rated 5A at 120V AC, continuous resistive load or clamped inductive load, 2A at 240V-AC, for 500,000 operations.

1.2.2 **WARNING:** Turn off all power supply sources and follow Lockout/Tagout Procedures while working on pendant.

1.3 Environmental Specifications

1.3.1 **WARNING!** Use only mild detergents for cleaning pendant housings. Solvents and brake cleaners will damage the housings.

2.0 SPECIFICATIONS

2.1 Disassembly of the Enclosure (See Figure 1)

2.1.1 Remove Bushing and Collar by loosening the bushing collar screws.

2.1.2 Remove Enclosure Cover by loosening the enclosure screws.

DISASSEMBLY AND ASSEMBLY OF THE ENCLOSURE FIGURE 1

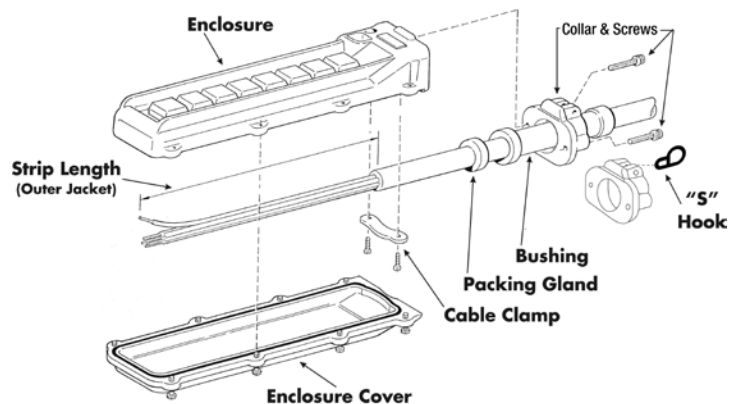

2.2 Mounting Switches (See Figure 1 & Figure 2, page 4)

2.2.1 Skip to Section 2.4 if pendant is preassembled.

2.2.2 Remove Enclosure Cover if not already removed.

2.2.3 Remove the Silicon Switch Boot for switches not requiring a boot. On/Off switches are provided with green and red boots. Swap boots as needed before installing switches.

2.2.4 Fit switch into Enclosure casing, aligning screw holes. Ensure Switch Boot is properly in place. Damaged or incorrectly installed boots will not seal properly, and moisture may leak inside the enclosure. Tighten Switch Screws securely. (Depending on switch, there will be either two or four screws.) Torque to 20 in-lbs.

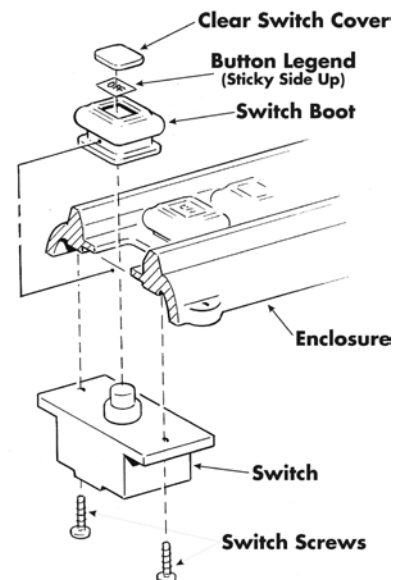

BUTTON SWITCH FIGURE 2

2.0 SPECIFICATIONS

2.3 Mounting Mushroom Head and Selector, Switches

2.3.1 Remove Enclosure Cover if not already removed.

2.3.2 Install Switch Frame by inserting it from the front of the enclosure through the square hole. Make sure the gasket and legend are in the correct position. From the back, install the Tightening Ring, making sure to align notches of Tightening Ring with tabs of Switch, and tighten (see figure 3a).

2.3.3 Install Switch to enclosure by using two screws provided. Make sure the designated letters on the Switch read correctly from the top of the enclosure.

2.3.4 Follow section 2.4 for cable installation, and wire as needed. (See Switch Schematics Section 3.0 Pages 6-7).

2.3.5 Apply appropriate legend label from the Selector Legend Sheet. Note: Legend Sheet is provided with Selector, Mushroom and on/off switches.

Important: Firmly fasten Tightening Ring to secure Frame. Align the notches for the Tightening Ring with the screw holes in the Enclosure. The Switch has tabs that fit into the cut-outs on the Frame. Misalignment will prevent the switch from seating properly

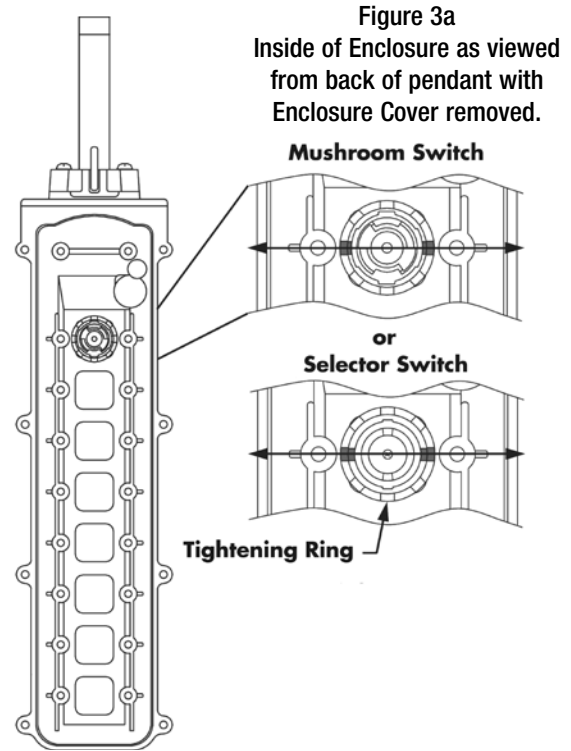

2.4 Cable Installation (See Figure 1, Page 3)

2.4.1 Disassemble pendant according to instructions in Section 2.1

2.4.2 Cut the two Packing Glands apart and use only one. The Glands are labeled in millimeters. (See Table 2.4.2). Be sure to choose the correct cable gland for the cable used. If the cable gland is loose, an adequate seal will not be achieved and moisture may leak inside the enclosure.

Table 2.4.2

| Part Number | Diameter / Inches | Diameter / Millimeters |
|-------------|-------------------|------------------------|
| 34411 | .295 - .354 | 7.50 - 9.00 |
| | .346 - .413 | 8.80 - 10.5 |
| 34412 | .406 - .472 | 10.3 - 12.0 |
| | .464 - .531 | 11.8 - 13.5 |
| 34413 | .524 - .591 | 13.3 - 15.0 |
| *39825 | .583 - .650 | 14.8 - 16.5 |
| 34414 | .642 - .709 | 16.3 - 18.0 |
| *39826 | .701 - .768 | 17.8 - 19.5 |
| 34415 | .760 - .827 | 19.3 - 21.0 |
| | .819 - .886 | 20.8 - 22.5 |
| 34416 | .878 - .945 | 22.3 - 24.0 |
| | .937 - 1.004 | 23.8 - 25.5 |
| 34417 | .996 - 1.063 | 25.3 - 27.0 |
| | 1.055 - 1.122 | 26.8 - 28.5 |
| 34418 | 1.114 - 1.161 | 28.3 - 29.5 |

* 39825 & 39826 used on enclosures with large collar.

2.4.3 Pull cable through the Bushing Collar, Bushing, and Packing Gland. Then feed the cable through the cable hole of Enclosure casing. Determine amount of outer jacket that needs to be stripped. Strip the outer jacket.

2.4.4 Position cable so that the Cable Clamp will clamp the jacketed part of the cable. Secure the cable by installing the Cable Clamp and tightening Cable Clamp Screws.

2.4.5 Secure the Bushing and Collar firmly to the enclosure casing with the two Collar Screws after adjusting wiring length and clamping cable.

2.4.6 NOTE: Tighten all applicable screws using the recommended torque values in Section 1.1.4

2.4.7 Connect wiring connections to the push button terminals using UL listed ring terminals. (See Switch Schematics on Page 6-7.) Wire lengths must be a minimum of 6" long according to NEC code. Route wires along the inside of housing. Never leave wires on top of switch due to interference with back cover installation.

2.0 SPECIFICATIONS

2.5 Button Legends PN: 34326 (A Button Legend Sheet is supplied with all pre-assembled pendants. Switch covers are sent loose with all pendants.)

2.5.1 Select the appropriate label from the Legend Sheet. Carefully remove from sheet. Labels have adhesive on the printed side. Carefully place label on larger side of the Clear Switch Cover.

2.5.2 Place one edge of labeled Switch Cover in appropriate Switch Boot. Complete installation by gently lifting rim of boot over remaining edges of Switch Cover.

2.6 Vertical Legends PN: 34327

2.6.1 Select the appropriate label from the Legend Sheet. Carefully remove from sheet. Labels have adhesive on the backside. Carefully place label on Enclosure casing beside appropriate switch.

2.7 Reassembly of the Enclosure (See Figure 1, Page 3)

2.7.1 Ensure that all conductors are insulated from one another.

2.7.2 Ensure that the Enclosure Seal Gasket is in place in the slot of the Enclosure Cover.

2.7.3 Remove all wire waste and debris from inside the Enclosure Case.

2.7.4 Install the Enclosure Cover and tighten Enclosure Screws.

3.0 SWITCH SCHEMATICS

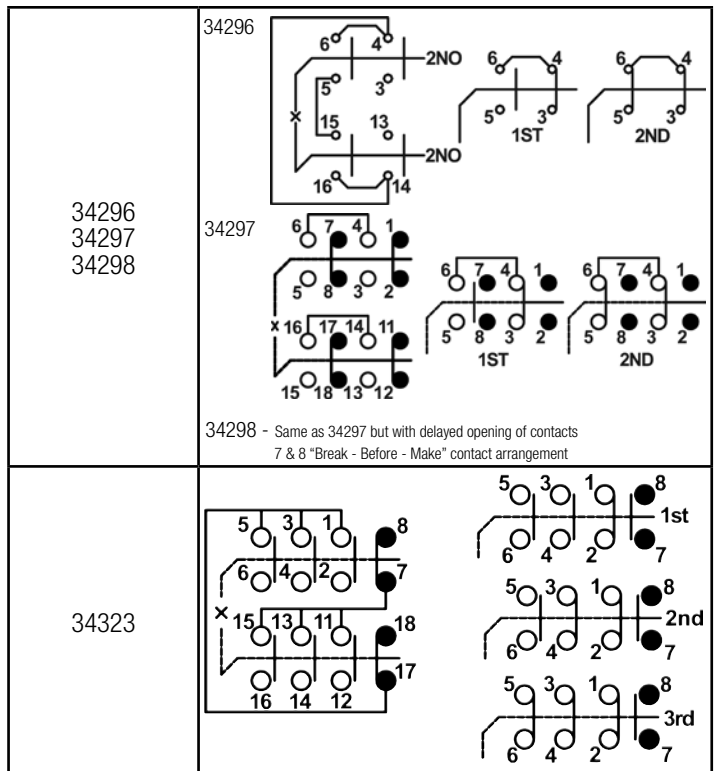
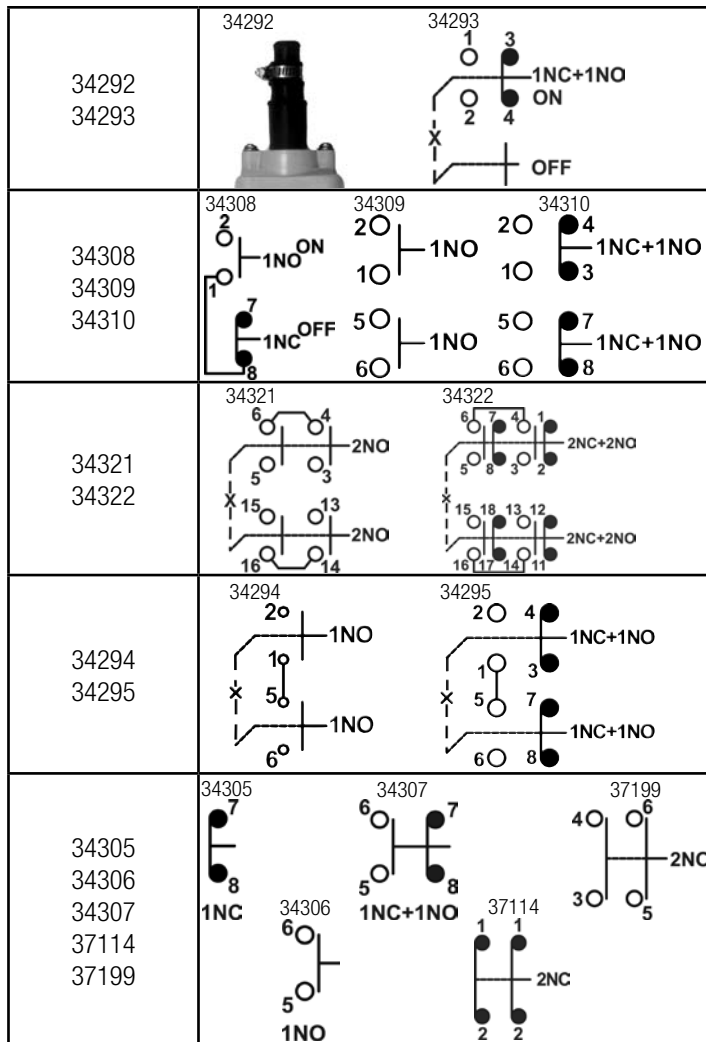

3.0 SWITCH SCHEMATICS

| | |
|--|--------------------------------------|
| 37107 37108 34317 34318 34319 34320 37109 37110 | |
| 34313 37122 37123 37124 37125 | |
| 34299 34300 37126 | |
| 34301 34302 37127 | |
| 34314B - (1K) 34314D - (2K) 34314 - (5K) 34314C - (10K) | |
| 34304 | Blind rubber gasket with metal plate |

| P/N | Switch Description |
|--------|--|
| 34292 | Maintained On-Off, 1NO |
| 34293 | Maintained On-Off, 1NC 1NO |
| 34308 | Momentary On-Off, 1NC, 1NO |
| 34309 | Momentary, 2NO, w/o interlock |
| 34310 | Momentary, 2NC, 2NO, w/o interlock |
| 34321 | Momentary, 4 NO w/interlock |
| 34322 | Momentary, 4NC, 4NO, w/interlock |
| 34294 | Momentary, 2NO w/interlock |
| 34295 | Momentary, 2NC, 2NO w/interlock |
| 34305 | Momentary, 1NC |
| 34306 | Momentary, 1NO |
| 34307 | Momentary, 1NC, 1NO |
| 37114 | Momentary, 2NC |
| 37199 | Momentary, 2NO |
| 34296 | 2-Speed, 4NO, w/interlock |
| 34297 | 2-Speed, Double Contact, 2NC, 4NO, w/interlock |
| 34298 | 2-Speed, Double Contact, 2NC, 2NO x 2 w/interlock (Late Break) |
| 34323 | 3-Speed, 1NC, 6NO |
| 37107 | 2 Position Selector, 1NC |
| 37108 | 2 Position Selector, 1NO |
| 34317 | 2 Position Selector, 1NC, 1NO (A-B) |
| 34318 | 2 Position Selector, 2NO |
| 34319 | 3 Position Selector, 2NC, (A-Both-B) |
| 34320 | 3 Position Selector, 2NO (A-Off-B) |
| 37109 | 2 Position Selector, 2NC |
| 37110 | 3 Position Selector, 1NO, 1NC |
| 34313 | Mushroom, 30mm, Red, 1NC (HORN) |
| 37122 | Mushroom, 30mm, Red, 1NO |
| 37123 | Mushroom, 30mm, Red, 1NO, 1NC |
| 37124 | Mushroom, 30mm, Red, 2NC |
| 37125 | Mushroom, 30mm, Red, 2NO |
| 34299 | Alternative, 1NO |
| 34300 | Alternative, 1NC, 1NO |
| 37126 | Alternative, 2NO |
| 34301 | 1NO |
| 34302 | Toggle, 1NC, 1NO |
| 37127 | Toggle, 1NO, 1NC |
| 34314B | Variable Position Resistor (1K) |
| 34314D | Variable Position Resistor (2K) |
| 34314 | Variable Position Resistor (5K) |
| 34314C | Variable Position Resistor (10K) |
| 34304 | Blind Rubber Gasket with metal plate |

www.conductix.com

Conductix-Wampfler

10102 F Street
Omaha, NE 68127
USA

Customer Support
Phone: 800 521 4888
Fax: 800 780 8329

Phone: 402 339 9300
Fax: 402 339 9627

info.us@conductix.com
www.conductix.com

