

Conductor Bar Side Contact

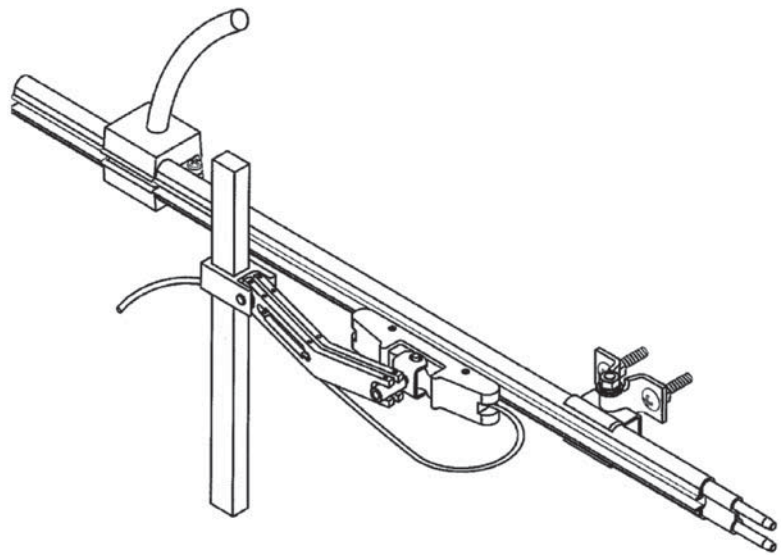

Conductix Incorporated

The technical data and images which appear in this manual are for informational purposes only. **NO WARRANTIES, EXPRESS OR IMPLIED, INCLUDING WARRANTIES OF MERCHANTABILITY OR FITNESS FOR A PARTICULAR PURPOSE, ARE CREATED BY THE DESCRIPTIONS AND DEPICTIONS OF THE PRODUCTS SHOWN IN THIS MANUAL.** Conductix makes no warranty (and assumes no liability) as to function of equipment or operation of systems built according to customer design or of the ability of any of its products to interface, operate or function with any portions of customer systems not provided by Conductix.

Seller agrees to repair or exchange the goods sold hereunder necessitated by reason of defective workmanship and material discovered and reported to Seller within one year after shipment of such goods to Buyer.

Except where the nature of the defect is such that it is appropriate, in Seller's judgment, to effect repairs on site, Seller's obligation hereunder to remedy defects shall be limited to repairing or replacing (at Seller's option) FOB point of original shipment by Seller, any part returned to Seller at the risk and cost of Buyer. Defective parts replaced by Seller shall become the property of Seller.

Seller shall only be obligated to make such repair or replacement if the goods have been used by Buyer only in service recommended by Seller and altered only as authorized by Seller. Seller is not responsible for defects which arise from improper installation, neglect, or improper use or from normal wear and tear.

Additionally, Seller's obligation shall be limited by the manufacturer's warranty (and is not further warranted by Seller) for all parts procured from others according to published data, specifications or performance information not designed by or for Seller.

Seller further agrees to replace or at Seller's option to provide a refund of the sales price of any goods that do not conform to applicable specifications or which differ from that agreed to be supplied which non-conformity is discovered and forthwith reported to Seller within thirty (30) days after shipment to the Buyer. Seller's obligation to replace or refund the purchase price for non-conforming goods shall arise once Buyer returns such goods FOB point of original shipment by Seller at the risk and cost of Buyer. Goods replaced by Seller shall become the property of Seller.

There is no guarantee or warranty as to anything made or sold by Seller, or any services performed, except as to title and freedom from encumbrances and, except as herein expressly stated and particularly, and without limiting the foregoing, **there is no guarantee or warranty, express or implied, of merchantability or of fitness for any particular purpose or against claim of infringement or the like.**

Seller makes no warranty (and assumes no liability) as to function of equipment or operation of systems built to Buyer's design or of the ability of any goods to interface, operate or function with any portions of Buyer's system not provided by Seller.

Seller's liability on any claim, whether in contract, tort (including negligence), or otherwise, for any loss or damage arising out of, connected with, or resulting from the manufacture, sale, delivery, resale, repair, replacement or use of any products or services shall in no case exceed the price paid for the product or services or any part thereof which give rise to the claim. In no event shall Seller be liable for consequential, special, incidental or other damages, nor shall Seller be liable in respect of personal injury or damage to property not the subject matter hereof unless attributable to gross misconduct of Seller, which shall mean an act or omission by Seller demonstrating reckless disregard of the foreseeable consequences thereof.

Seller is not responsible for incorrect choice of models or where products are used in excess of their rated and recommended capacities and design functions or under abnormal conditions. Seller assumes no liability for loss of time, damage or injuries to property or persons resulting from the use of Seller's products. Buyer shall hold Seller harmless from all liability, claims, suits and expenses in connection with loss or damage resulting from operation of products or utilization of services, respectively, of Seller and shall defend any suit or action which might arise there from in Buyer's name - provided that Seller shall have the right to elect to defend any such suit or action for the account of Buyer. The foregoing shall be the exclusive remedies of the Buyer and all persons and entities claiming through the Buyer.

INDEX

- 1.0 Safety Instructions
- 2.0 Installation
- 3.0 Special Applications
- 4.0 Operation
- 5.0 Maintenance
- 6.0 Troubleshooting
- 7.0 Replacement Parts

1.0 Safety Instructions

1.1 Safety Warnings

- 1.1.1 Disconnect Power and follow all lock-out tag-out procedures as described in Appendix A of OSHA Section 1910.147.
- 1.1.2 All personnel must practice strict adherence to both local and national safety procedures, codes, regulations, and ordinances.
- 1.1.3 All personnel installing a power rail system should be familiar with the layout details and the component locations.
- 1.1.4 **Warning:** The law recognizes that electrical energy as commonly utilized in industrial and transit operations is dangerous and capable of causing serious damage, injury or death. Requirements governing the handling and use of electricity, some general and some very specific and detailed, are found in various statutes like the **Workmen's Compensation Acts, Employer's Liability Acts, National Electrical Safety Code** (U.S. Dept. of Commerce), **Occupational Safety and Health Administration** (OSHA), etc. and city or local ordinances. When using electrical power, the law imposes the general obligation to use care to protect against accidental injury or damage to properties.

2.0 Installation

2.1 General Notes

2.1.1 Required Hand Tools

- Torque Wrench
- Socket Wrench Set
- Small Ball Peen Hammer
- Hacksaw
- Screwdriver Set
- 3/8" Drill & Drill Bit Set
- Small File Set

2.1.2 All Installations

- 2.1.2.1 Store conductor bar overnight in the installation environment to assure that all bar has equalized to the ambient air temperature. The bar must be installed with a relatively uniform temperature to allow proper gauging of the expansion section gap setting.

2.1.3 Standard Mounting

- 2.1.3.1 Side Contact conductor bar is typically installed with bar profile oriented laterally and the collector shoe entering from the side.

2.1.4 Nomenclature

- 2.1.4.1 **Anchor Tight:** The clamping force required to overcome movement due to the heating and cooling of the conductor bar (60 in-lbs).
- 2.1.4.2 **Sliding Tight:** The clamping force required to hold the bar in place while allowing movement due to the heating and cooling of the conductor bar. Hanger Clamps are designed to provide a sliding tight fit (30 in-lbs).
- 2.1.4.3 All hangers that are not specified to be anchor tight must be installed sliding tight to assure reliable operation.

- 2.1.5 **Additional Information:** Any questions about the installation or use of Conductix-Wampfler Conductor Bar that are not addressed in this manual can be answered by Conductix-Wampfler Engineering. **Contact the factory: (800) 521-4888**

2.0 Installation

2.3 Hanger Clamp and Bracket Assemblies

2.3.1 Single Conductor Hanger Clamps

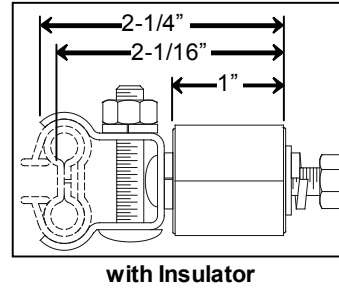
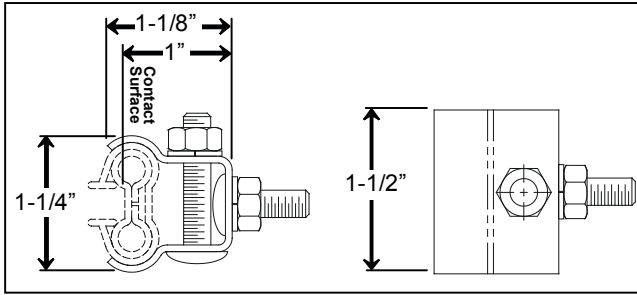

2.3.2 Multi-Conductor Hanger Clamps and Bracket Assemblies

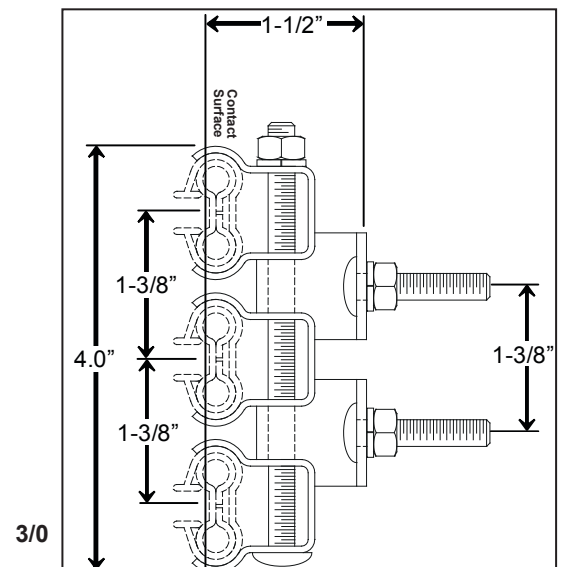
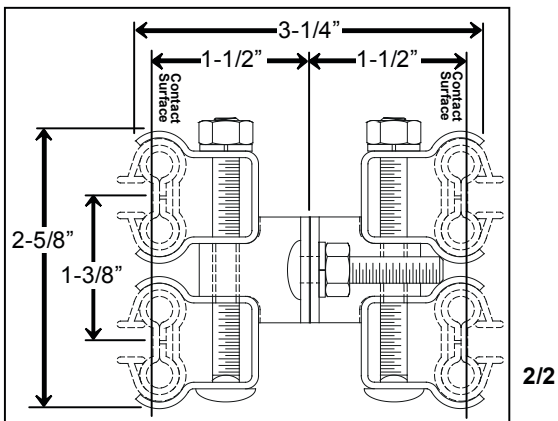
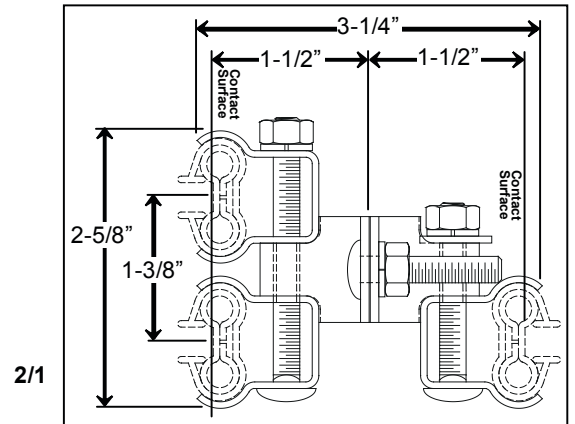
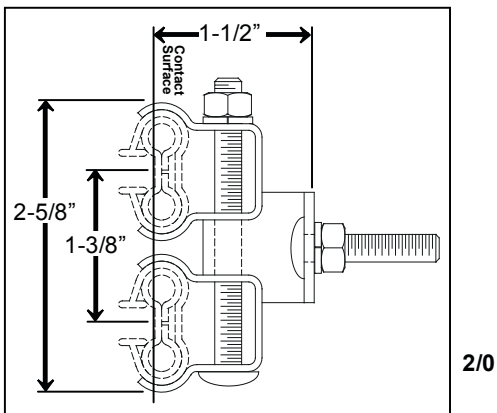
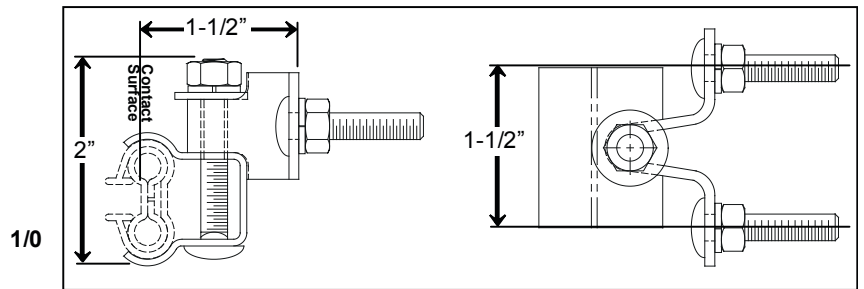
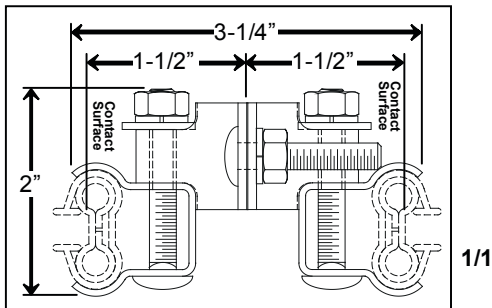

2.0 Installation

2.4 Web Mounted Conductors

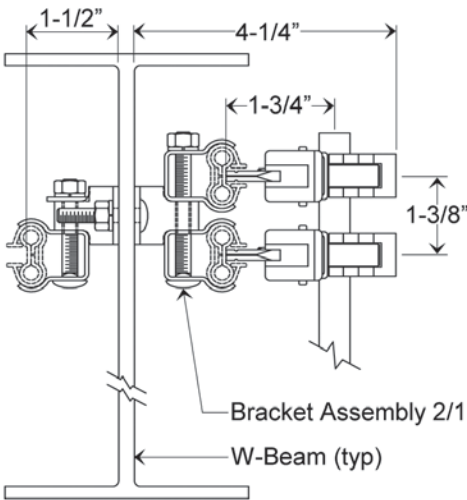

<< Web Mounted on Flanged Monorail >>
(“M” Head, “L” Base Collector shown.)

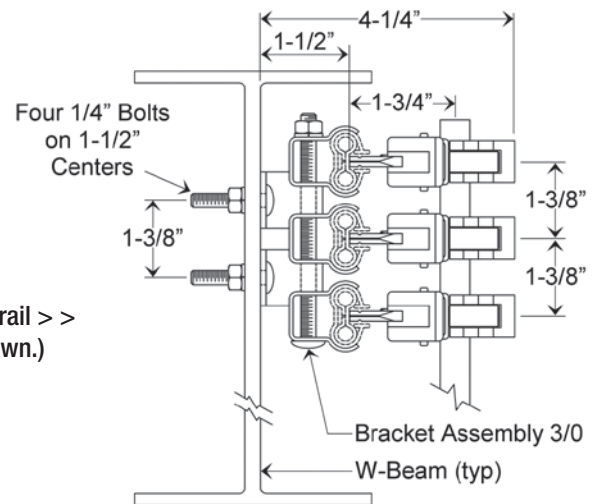

2.4.1 **Note:** Trolleys on which collectors are mounted must be stabilized, particularly in discontinuous circuit systems. An acceptable method uses guide rollers on the edge of the track flange.

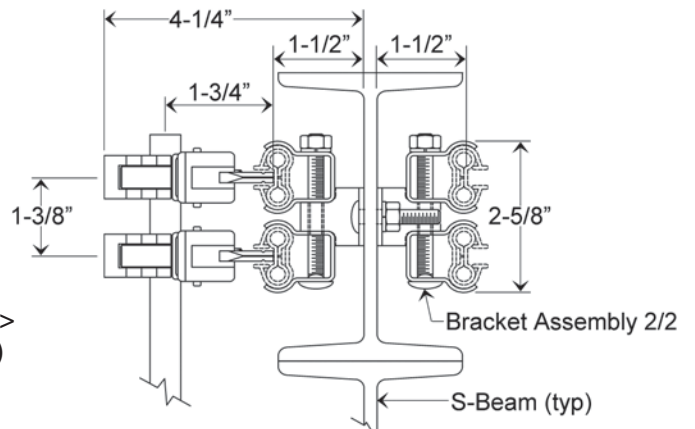

Web Mounted on Conveyor Tracks >>>
(“M” Head, “L” Base Collector shown.)

2.5 Typical Layout for Straight Runways

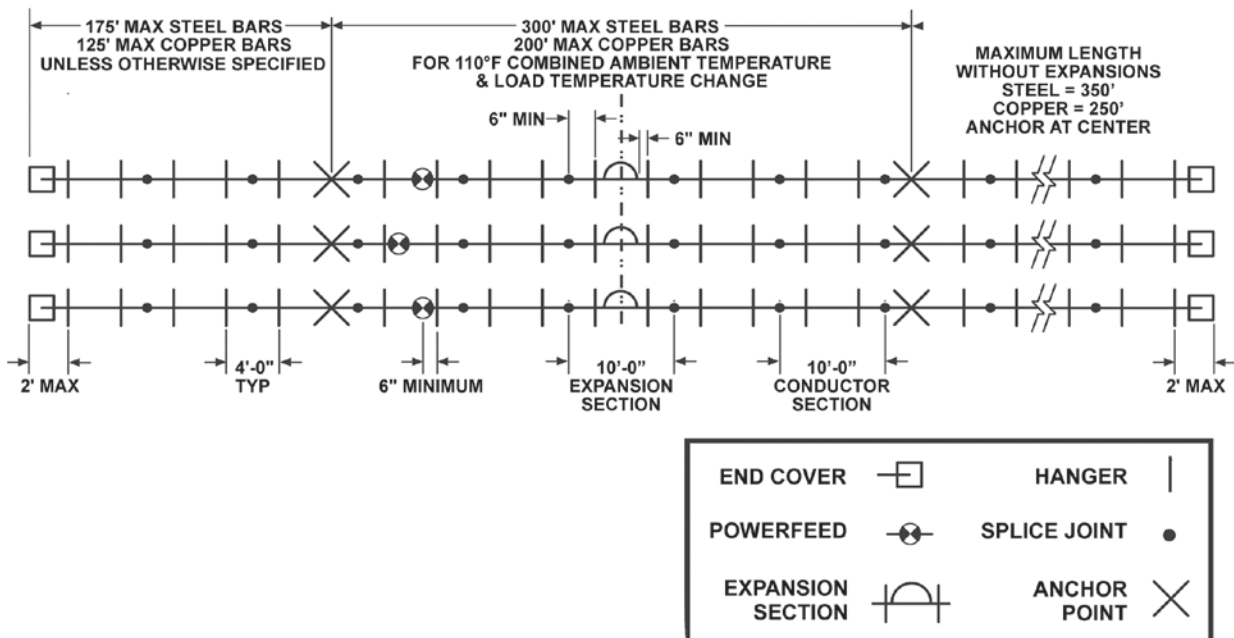

2.5.1 Installations that include curved sections require special consideration. Please contact the factory for assistance.

2.0 Installation

2.6 Typical Collector Mounting

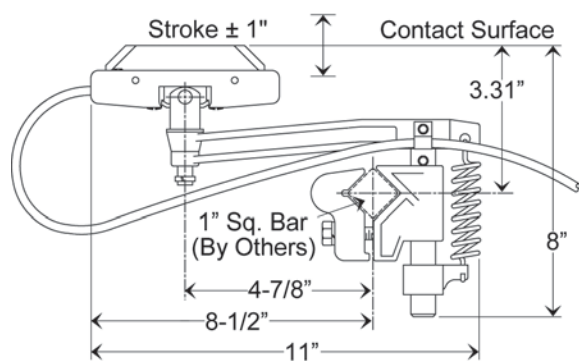

“M” Head, “H” Base Collector

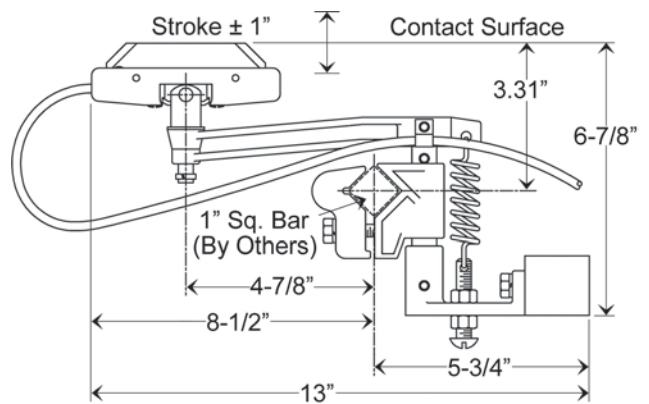
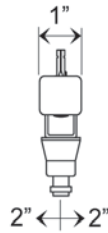

“M” Head with Counterbase Collector

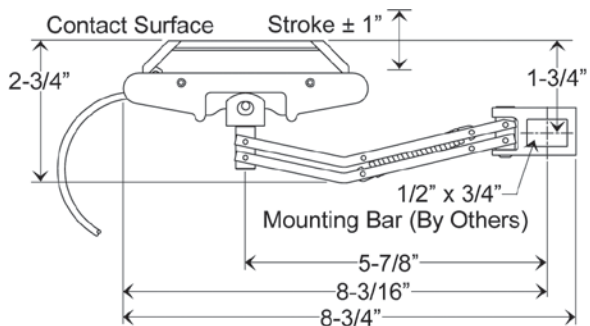

“M” Head, “L” Base Collector

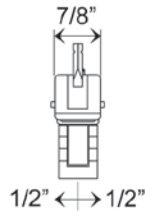

2.6.1 **Caution:** Do not use collectors as power switching devices, since resultant arcing may cause rapid deterioration of both the contact shoes and conductor bars.

2.6.2 Ampere capacity of conductor bars, powerfeeds, jumpers, etc., should be the same as specified for the system.

2.6.3 Consult factory for systems using tandem mounted collectors and special requirements.

2.6.4 Contact Shoe Pressure: All collectors — 4 to 6 lbs.

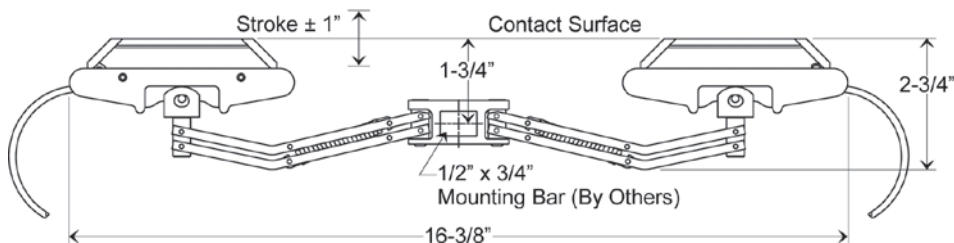

“M” Head, “L” Base Collector, Tandem

2.7 Expansion Sections

2.7.1 Expansion Sections are installed in the same manner as standard 10' Sections of Conductor Bar. (See Section 2.5.)

2.7.2 Expansion sections are shipped with two guide bracket clamps secured anchor tight and the other two guide bracket clamps at sliding tight. Note that the anchor tight side is the side with the pin installed at the end of the bar. (see Fig. 2.7.2 on the next page.)

2.7.3 After the expansion section has been installed, set the expansion gap according to the Table 2.7.3 on the following page.

2.7.4 Tighten the two sliding tight guide bracket clamps anchor tight. Note that the ones to be tightened are on the side without the pin at the end of the conductor bar. Proceed with installation of the remaining conductor bars.

2.7.5 **IMPORTANT:** After all conductor bars have been installed, loosen the two clamp bolts on one side of guide bracket which was tightened to anchor tight (as done in 2.7.4 above) on all expansion sections to sliding tight. Recheck the expansion gap after installation and adjust if necessary.

2.7.6 Location of expansion sections is critical for proper functioning of the system. Follow installation drawing, or, if no drawing is available, refer to Fig. 2.7.6 on the next page.

2.0 Installation

Fig. 2.7.2 Expansion Gap and Anchoring Requirements

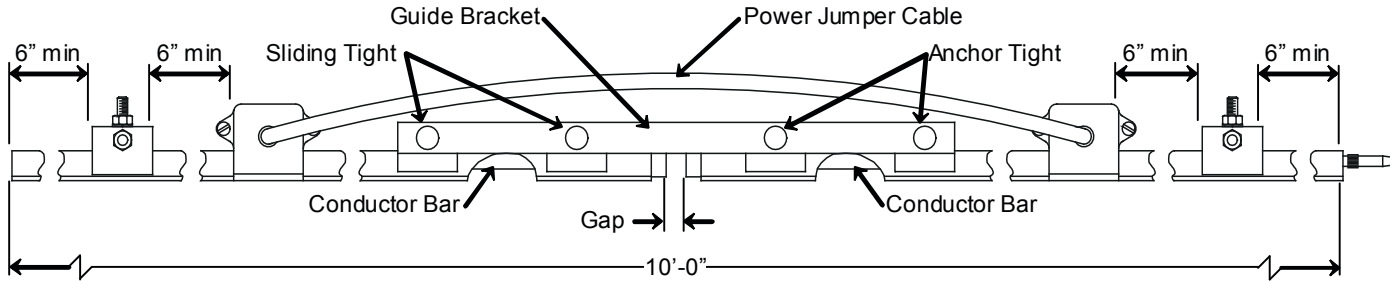
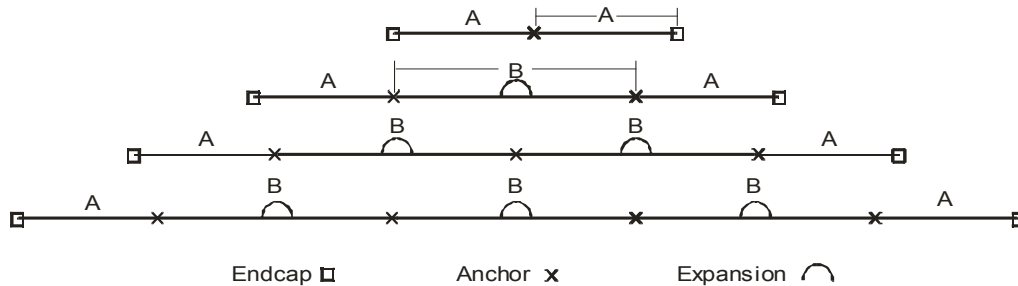

Table 2.7.3 Expansion Gap Settings Table

Ambient Temp Range (°F)	0°-100°F					20°-120°F					40°-140°F				
Ambient Temp (°F)	0	25	50	75	100	20	45	70	95	120	40	65	90	115	140
Gap Setting (in)	2.50	1.94	1.38	0.8	0.25	2.50	1.94	1.38	0.81	0.25	2.50	1.94	1.38	0.81	0.25

Fig. 2.7.6 Expansion and Anchor Diagram

	<u>A MAX</u>	<u>B MAX</u>
Steel Bar -	175 Ft.	300 Ft.
Copper Bar -	125 Ft.	200 Ft.



2.8 Installation Procedure

Step 1 Install Hanger & Anchor Clamps

- 2.8.1 Attach hanger clamps to hanger brackets as required.
- 2.8.2 Mount side contact conductor hanger clamp and bracket assemblies on steelwork at 4 ft. (3 ft. on curves) Conductor minimum centerline spacing 1-3/8" (Torgue 8-12ft. Lbs).
- 2.8.3 **Note:** To obtain proper alignment, do not tighten *Single Conductor Hanger Clamp* bolts until all conductor bar is installed.
- 2.8.4 All hanger clamps must be sliding tight (30 in-lbs) on straight runways except at anchor points (30 in-lbs). Check layout drawings for anchor point locations. If there are no drawings, anchor at the center of the runway or in center between expansion sections.
- 2.8.5 **CAUTION:** If hanger clamp bolts are tightened too much, they can compress the cover until the collector shoes will not clear.

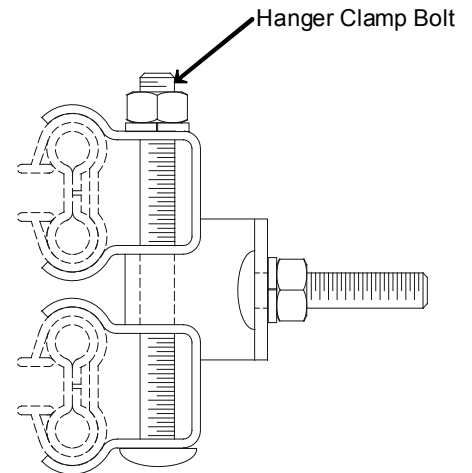

Fig. 2.8.3

2.0 Installation

Step 2 Install Conductor Bar

2.8.6 Install conductor bar. (For expansion section installation see Section 2.7.)

2.8.7 Snap side contact conductor into hanger clamp then tighten mounting bolt (see Fig. 2.8.4).

Step 3 Join Conductor Bar

2.8.8 Join conductor lengths using connector tool provided.

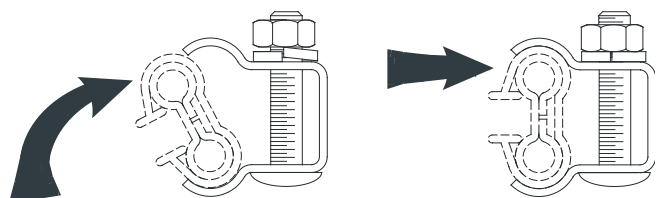
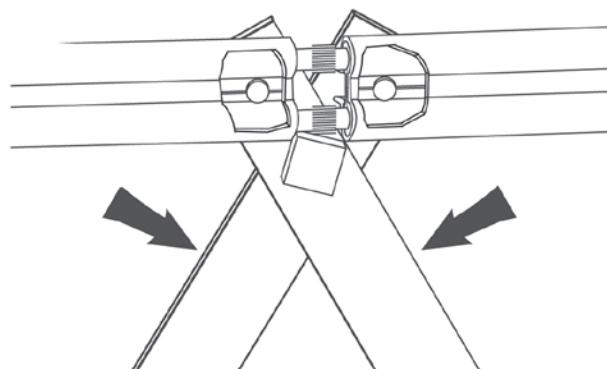

Fig. 2.8.4



Step 4 Install Powerfeeds

2.8.9 Install Powerfeeds at locations shown on installation drawings. If no drawing was provided, locate powerfeeds at any point along a straight run, staggered between adjacent conductors (see Fig. 2-8.13). When possible, locate at a joint (or toward the center of standard conductor lengths) in order to avoid creating short lengths of cover which can work loose.

2.8.10 Cut out a 1 13/16" section of cover for each powerfeed (see Fig. 2.8.10).

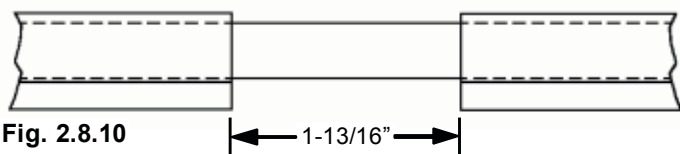

Fig. 2.8.10

2.8.11 Each Powerfeed Assembly includes:

Item	Quan.	Description
A	1	Terminal Clamp
B	1	Clamp Half
C	2	Socket Bolt, H'D, 1/4-20 x 3/4
D	4	Setscrew, 3/8-16 x 1/2
E	2	Case Half
F	2	Binding Screw, H'D, 8-32 x 1/2
G	2	Jam Hex Nut, 8-32
H	2	Shockproof Washer, #8

(See Figs. 2.8.11 and 2.8.12.)

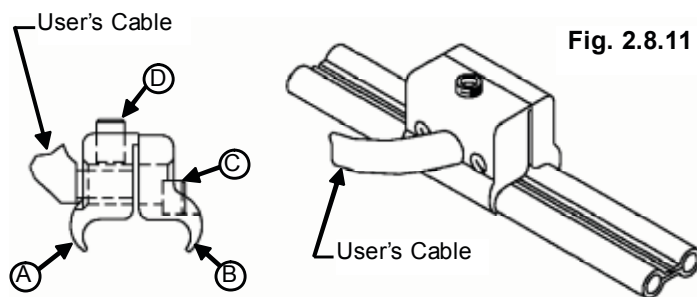

Fig. 2.8.11

2.8.12 Remove the knockout from one of the case halves to allow the cable insulation to completely enter the cover and lay flush against the powerfeed. Drill open the knockout for larger cable as required. (See Fig. 2.8.12).

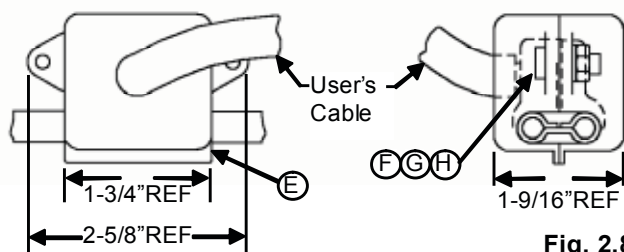

Fig. 2.8.12

2.8.13 **NOTE:** The customer's cable should be flexible enough to allow movement of the bar as it expands and contracts. Also, powerfeeds must be offset on adjacent conductors to allow for proper cable clearance (see Fig. 2.8.13).

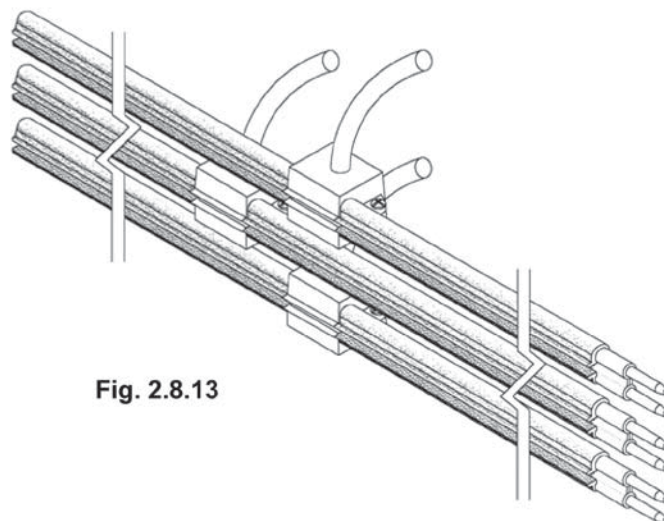
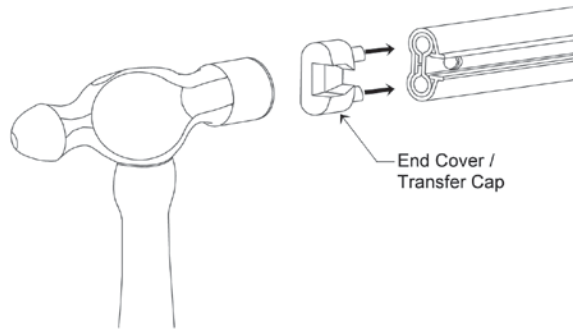

Fig. 2.8.13

2.0 Installation

Step 5 Install End Covers/Transfer Caps

2.8.14 Center pins of End Cover/Transfer Cap on the end of the bar. Tap lightly with a hammer until securely seated.



Step 6 Install Collectors

2.8.15 Refer to installation dimensions in Section 2.6.

Step 7 Final Inspection

2.8.16 Sight down the installed conductor runs and straighten any areas where conductor bar is out of alignment. Verify all mounting bolts on hangers are torqued to their proper values.

2.8.17 Make sure collectors are aligned properly with the conductor bar.

2.8.18 Check the distance between the centerline of the collector mounting staff and contact surface of conductor bar.

2.8.19 Make sure anchor clamps are properly positioned and anchor tight.

2.8.20 Make sure clamps on one side of expansion section have been made sliding tight. Verify that the expansion section air gap is correct for the ambient bar temperature.

2.8.21 Check all electrical connections.

2.8.22 Prior to introducing the system to service, run the application at slow speed through the entire runway length in both directions to verify operation. This will also allow you to identify any potential obstacles that were overlooked during installation. Pay special attention to Collector Arm movements. The alignment of collector to collector (phase to phase) should be relatively uniform.

3.0 Special Applications

3.1 Field Cutting

3.1.1 Cut conductor and cover with a hacksaw to desired length.

3.1.2 Deburr/File field cut end as necessary.

3.1.3 Ream conductor lobes:
40, 110-350 amp bar — “D” size drill bit
90 amp bar — “M” size drill bit

3.1.4 Install as usual.

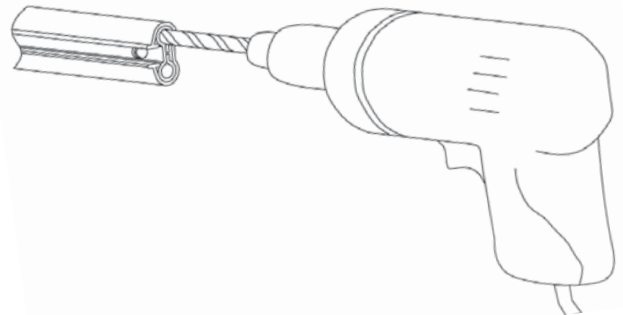

3.2 Curves

3.2.1 Install curved sections of conductor bar before any straight sections.

3.2.2 Maximum hanger spacing on curves is 3 ft.

3.2.3 Curves are generally anchored at the apex, at midway between the straight sections. Contact the factory with specific application questions for further information.

3.0 Special Applications

3.3 Discontinuous Systems

- 3.3.1 Install Pick-up Guides using the connector tool provided (see Step 3).
- 3.3.2 Hanger Clamp bolts on Pick-up Guides are required to be anchor tight.
- 3.3.3 Collectors should not be used to interrupt current.

Note: Self-centering Collectors must be used with pick-up guide.

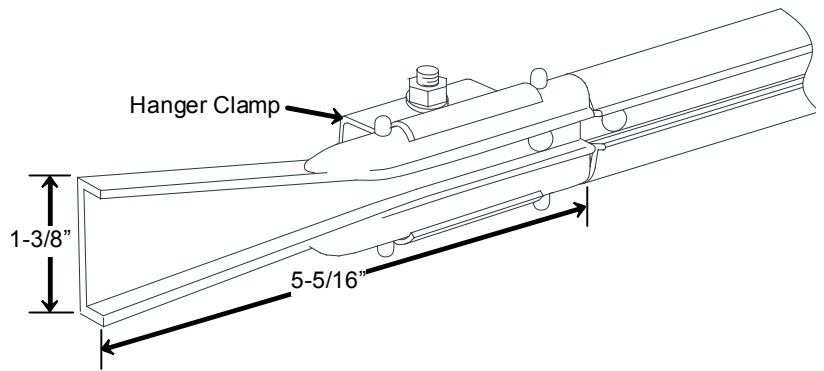

3.4 Interlock, Switches, or Fixed Gaps

- 3.4.1 **Note: Make sure Hanger Clamps are anchor tight at location "X." Switch sections over 25 ft. may require an expansion section.**

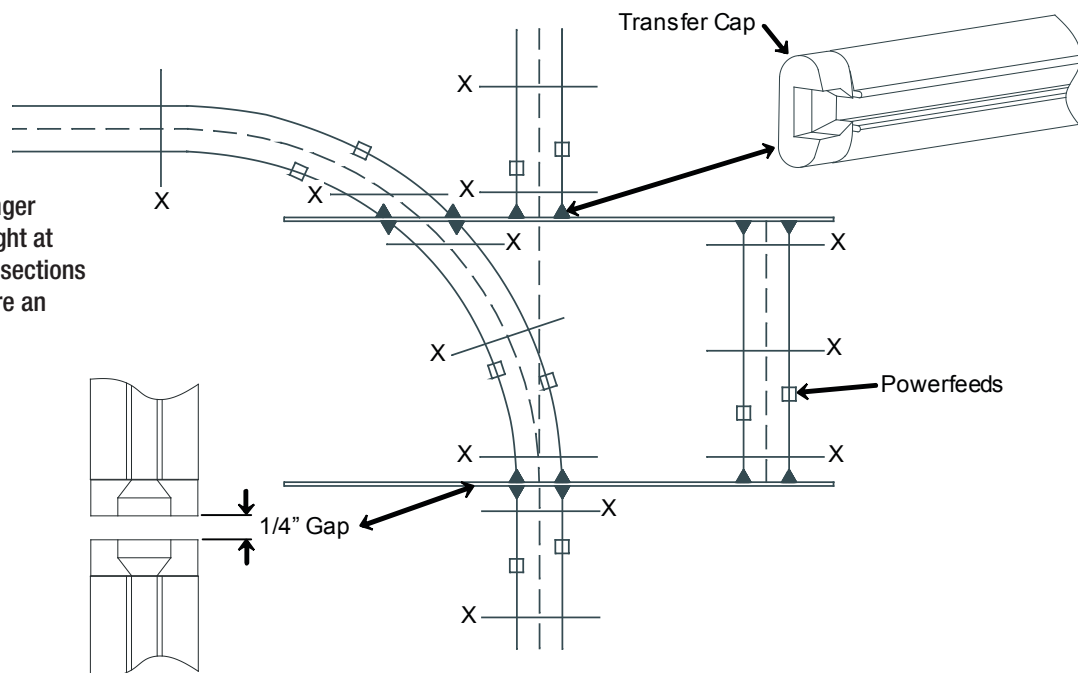

4.0 Operation

- 4.1 Sight down the installed conductor runs and straighten any areas where conductor bar is out of alignment. Verify all mounting bolts on hangers are secure.
- 4.2 Make sure collectors are aligned properly with the conductor bar.
- 4.3 Check the distance between the centerline of 1/2" x 3/4" flat bar collector mounting staff and contact surface of conductor bar. Distance should be 1-3/4". **Note:** If using "M" Head, "H" Base collector, distance from centerline of 1" square bar to contact surface is 3-3/4".
- 4.4 Make sure anchor clamps are properly positioned and anchor tight.
- 4.5 Make sure clamps on one side of expansion section have been made sliding tight. Verify that the expansion section air gap is correct for the ambient bar temperature.
- 4.6 Make sure, if applicable, all joint keepers are securely in place.
- 4.7 Check all electrical connections.
- 4.8 Prior to introducing the system to service run the application at slow speed through the entire runway length in both directions to verify operation. This will also allow you to identify any potential obstacles that were overlooked during installation. Pay special attention to Collector Arm movements. The alignment of collector to collector (phase to phase) should be relatively uniform.

5.0 Maintenance

- 5.1 Contact shoes should be checked for wear on a monthly basis until a wear pattern can be established.
- 5.2 Check alignment of collector to conductor bars.
- 5.3 Check conductor system to ensure no damage to insulation cover.
- 5.4 In environments that are subject to considerable build up of dust, especially conductive dust, remove this dust at regular intervals by brushing.
- 5.5 Check that collector pivot points are free from any contamination.

6.0 Troubleshooting

- 6.1 Properly installed and normally inspected rigid conductor systems very seldom require extensive maintenance. When properly installed, shoe inspection and replacement is usually all that is necessary. The following table can be used as a normal maintenance check list, as well as a troubleshooting list.

Conductor Bar Troubleshooting		
Problem	Probable Cause	Solution
Burned joints of burned cover at joints	Loose joint, excess vibration, or over tightened hanger clamps. Joint Keeper not installed correctly.	Tighten joint, install joint keeper, check hanger clamps, and replace joint cover.
Distorted Cover	Too high ambient temperature, under-rated bar.	Use high or medium heat cover. Check total current draw under worst conditions.
Pitted or burned conductor	Improper shoe pressure or worn out shoe.	Check collector mounting and spring pressure. Check for worn out shoe. If the above are corrected and condition persists, install tandem collectors.
Damaging environment	Acid fumes, salt air, extremely dirty atmosphere.	May require copper or stainless steel conductor. Under these conditions conductor should always be mounted for vertical entry.
Collector Troubleshooting		
Problem	Probably Cause	Solution
Shoes wearing unevenly	Collector not mounted directly in line with conductor. Square bar is rotated out of square.	Remount or adjust collector.
	Lead wire not slacked.	Loosen lead wire.
	Collector movement too tight.	Free collector movement & lubricate.
Shoes pitted or burned	Insufficient shoe pressure. Excessive bouncing or hand-pulled trolley not stable.	Check shoe pressure and mounting distance. Excessive bouncing can be reduced with tandem collectors. Install guide rollers on hand pulled trolleys. Also see: Pitted or burned conductor.
De-tracking	Distorted cover or splice cover.	Check condition, replace as necessary.
	Misalignment at switches or crossovers.	Re-align and re-anchor. Check switch movement.
	Improperly installed.	Correct misalignment. Bad misalignment may require long arm collectors or expansion sections.
	Hanger clamp (cross-bolt type) too tight making bar "snake" to where collectors interfere with each other.	Loosen hangers so bar will slide. Tighten one hanger in center or between each expansion section.

Notes

Notes

Notes

www.conductix.com

Conductix-Wampfler

10102 F Street
Omaha, NE 68127
USA

Customer Support
Phone: 800 521 4888
Fax: 800 780 8329

Phone: 402 339 9300
Fax: 402 339 9627

info.us@conductix.com
www.conductix.com

